

EsMatix 3

Safety switching device for sensors with 8,2 kOhm

Original instructions

General

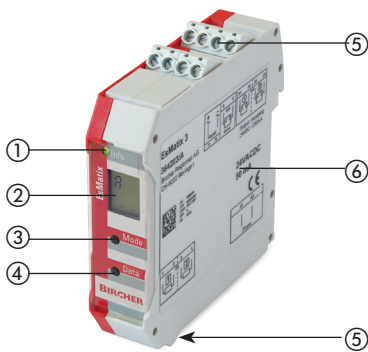

- ① LED
- ② LCD display
- ③ "Mode" button
- ④ "Data" button
- ⑤ Connecting terminals
- ⑥ Label

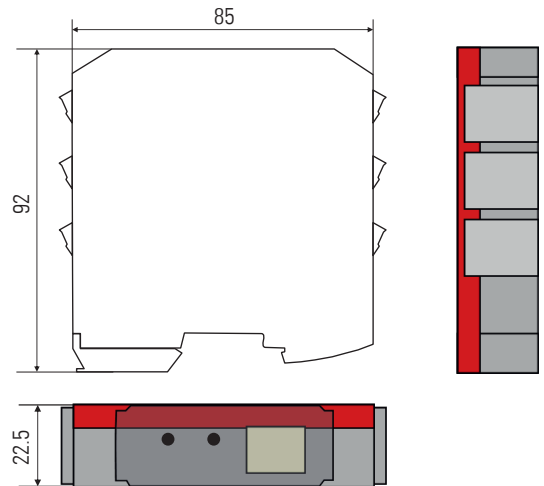

1 Safety Instructions



- The assembly, commissioning, modifications and extensions may only be completed by an experienced electrician!
- Before commencing work, remove the power supply from the device/ installations!
- During the operation of electrical components
 - e. g. in the case of a short circuit hot and ionised gases can be emitted
 - protection covers must not to be removed!
- Pay attention to all local relevant electrical safety regulations!
- Disregard of the safety regulations can cause death, severe injuries or extensive damage!
- Keep these operating instructions in a safe place for later use!

Before commencing the installation or assembly complete the following safety precautions:

- Check the voltage data on the type plate of the switching device.
- Ensure that the device/installations can not be switched on!
- Determine that the power supply is disconnected!
- Ground the phases and short circuit!
- Separate or cover neighbouring components which are connected to the power supply!
- Cover the device during assembly!
Foreign particles (e.g. borings from drilling) can damage the device.
- Protect the device with a housing against contamination or aggressive environments!

Limited protection against accidental contact!

2 Common Application

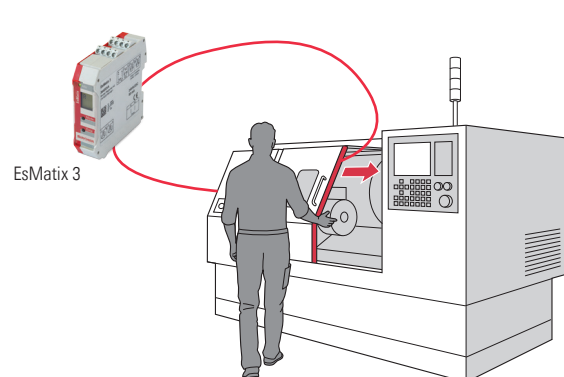
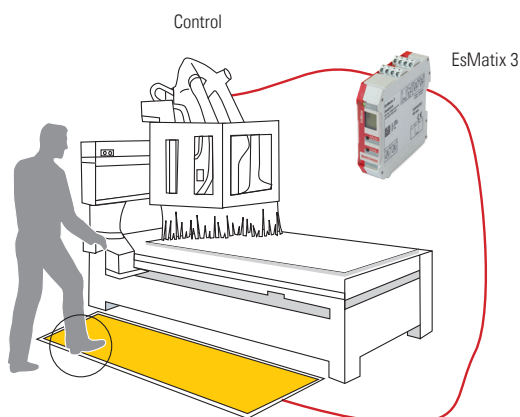

3 Function

Connected sensors with a terminating resistor of 8.2 kOhm are monitored for a change in current. In the idle mode

- all safety outputs are conductive
- the LED lights up green
- current reset-function appears on the display



When one or more sensors are **actuated**

- the total resistance of the sensor system drops to zero ohms
- the defined switching threshold is not reached anymore
- **both** output relays "Safety" open
- the LED lights up orange, P appears on the display



In the event of a **fault** in the sensor circuit (for example cable breakage)

- the total resistance of the sensor system increases
- the defined switching threshold is exceeded
- **both** output relays "Safety" open
- the LED lights up red, E appears on the display



Reset (Acknowledgment) of the switching device is carried out: Depending on the configuration

- By pressing and releasing the "data" button
- Automatically
- By applying and removing again an external reset signal to T1-T2

The recovery time after reset is < 30 ms (< 0.5 sec after a fault), then the LED lights green

Block diagram

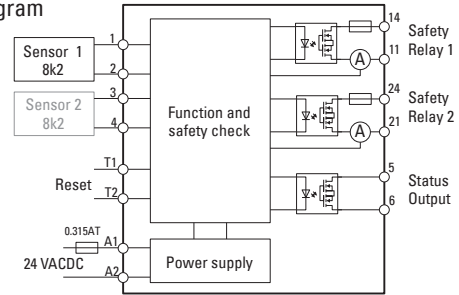

4 Connections, Settings

Examples: Wiring with autoreset

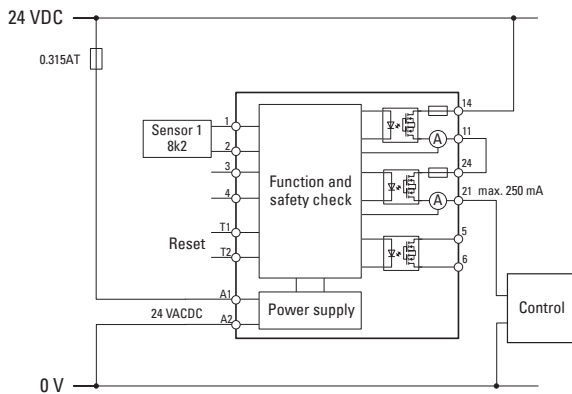

Wiring with external reset and EDM (external device monitoring)

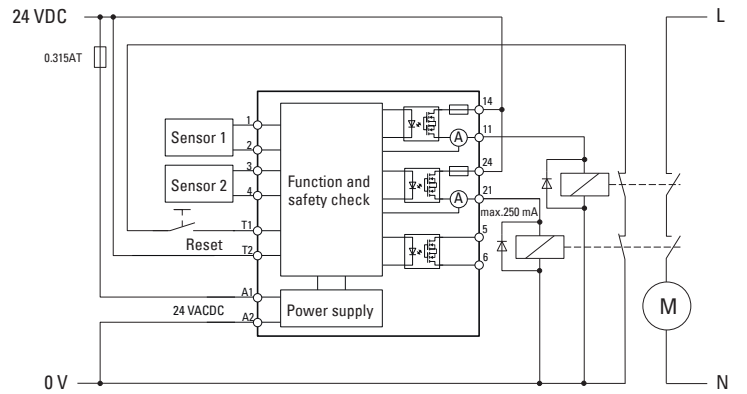

ⓘ In operation with external relays, freewheeling diodes are mandatory.

5 Configuration and set-up

5.1 Terminals

Wiring the device

- A1 / A2: Supply voltage (24 VDC or 24 VAC) ▲
- 1 / 2: Sensor 1
- 3 / 4: Sensor 2
- 11 / 14: Safety Relay 1 ▲
- 21 / 24: Safety Relay 2 ▲
- 5 / 6: Status output
- T1 / T2: Reset

- ⓘ No function test possible without connected outputs (Display E 007)
- ▲ Wiring mandatory

Switch on supply voltage

If necessary, configure the device

5.2 Function test

Function test

- Press sensor 1, check LED (orange), display (P, ①, ②, 1). Check if both outputs are open.
- Release sensor
- Manually reset device at reset type external (Et): close and reopen contact or at reset type internal (but): press and release button "Data"
- If present, press sensor 2, check LED, display (P, ①, ②, 2). Check if both outputs are open.
- Release sensor
- Manually reset device at reset type external (Et): close and reopen contact or at reset type internal (but): press and release button "Data"

After successful testing, the system is ready for operation.

Display: A and two flashing dots



5.3 Diagnostic menu (read only)

Data Mode Back to top Back to start

2 sec		E	r	C	a	L	I	h	O*	d	C
		Errors	Resistance	Configuration	Reset type	Reset logic	Reset input	Holding time	Status relay	Input delay	Configuration
		Error 5 latest	1 value	1 Sensor 1	Aut auto restart	LOA	Act active	no no	SC SC	no no	con
		Error 4	2 value								* no "O" at EsMatix 3.D con (flashing)
		Error 3									Access Configuration
		Error 2									
		Error 1									
		End									

Exit Diagnostic menu:

2 sec

Enter Diagnostic menu:

Press "Mode" and "Data" buttons simultaneously for 2 seconds
 → Status LED flashes orange
 To see the next parameter, press "Mode", Data query (Mode E and r):
 press "Data"

- E last 5 error messages (displayed by pressing "Data")
- r current resistances of the sensors (displayed in kOhm: 1, 2, 4, 6, 8, 10, 12 or 14)
- C shows the current configuration (active inputs):
1 = only input 1, 2 = both inputs 1 and 2
- a the programmed reset function:
Aut = auto restart, Et = external, but = internal (push button)
- L only if a = Et: Type of external reset signal:
LOA = (pulse low active), HIA = (pulse high active)
- I only if a = Et: status of the applied reset signal: Act = active, IdL = inactive
- h only if a = Aut: The holding time (extension of the output signal):
no = no, 0.1 = 100 ms, 0.2 = 200 ms, 0.5 = 500 ms, 1.0 = 1 s
- O only at EsMatix 3: type of the status output: Signaling contact = SC, Fault contact = FC (see table 5.4)
- d Input on delay: no = no, 15 = 15 ms, 30 = 30 ms, 45 = 45 ms
- C configuration: entering into the configuration mode by pressing "data" → Chap. 5.4

Exit Diagnostic menu:

Press "Mode" button for 2 seconds

5.4 Configuration mode (edit mode)

2 sec		C	a	L*	h*	O*	d
		Configuration	Reset	Reset Input	Holding time	Status relay	Input delay
		1 Sensor 1	Aut auto restart	LOA	no no	SC SC	no no
		2 Sensors 1+2	Et external	HIA	0.1 100 ms	FC FC	15 15 ms
			but Data button		0.2 200 ms		30 30 ms
					0.5 500 ms		45 45 ms
					1.0 1 s		

* no "O" at EsMatix 3.D
 "L" only at "a" = Et
 "h" only at "a" = Aut

Exit Configuration menu:

2 sec

On initial commissioning, the device must be adapted (configured) to the application.

Enter Configuration menu:

- Enter diagnostic menu: Press "Mode" and "Data" buttons simultaneously for 2 seconds.
- Press "Mode" repeatedly until "C" and "con" are displayed.
- Press "Data" button, "con" starts flashing.
- Press "Mode" and "Data" buttons simultaneously until "con" stops flashing. Green LED starts flashing fast.
- Release "Mode" and "Data", "C" starts flashing, both safety relays open.

Configuration

- Press the "Mode" button to select the requested parameter.
- Press the "Data" button to set the value.

Exit Configuration menu: Press "Mode" for 2 seconds.

Status Relays

Contacts	Type	Unpowered (LED off)	Sensor idle (LED green)	Sensor actuated (LED orange)	Fault (LED red)
FC (Fault contact)	EsMatix 3	OPEN	closed	closed	OPEN
SC (Signaling contact)	EsMatix 3	OPEN	closed	OPEN	OPEN
D (Signaling contact)	EsMatix 3.D	closed	OPEN	closed	closed
Safety contacts	all types	OPEN	closed	OPEN	OPEN

Adjustable parameters:

- C active inputs: 1 = only input 1, 2 = both inputs 1 and 2
- a type of reset: Aut = auto restart, Et = external, but = internal (push button)
- L only if a = Et: Type of external reset signal:
LOA = (pulse low active), HIA = (pulse high active)
- h only if a = Aut: The holding time (extension of the output signal):
no = no, 0.1 = 100 ms, 0.2 = 200 ms, 0.5 = 500 ms, 1.0 = 1 s
- O only at EsMatix 3:
type of the status output: Signaling contact = SC, Fault contact = FC → table below
- d Input on delay: no = no, 15 = 15 ms, 30 = 30 ms, 45 = 45 ms

5.5 Service mode

Data
 Mode
 Back to top
 Back to start

10 sec

H	S	t	U	o	E	E
Hardware version	Software version	Type	Supply voltage	Chip temperature	Errors flash	Errors flash
005	6.52	3	value	value	Error 5 latest	rES
					Error 4	---
					Error 3	
					Error 2	
					Error 1	
					End	

Enter Service mode: Press "Data" for 10 seconds

→ Green status LED flashes

To enter the next mode, press "Mode"

Data query in each mode: press "Data" button

Exit Service mode: Press "Mode" button for 2 seconds

In the service mode, further information can be queried:

H Hardware Version

S Software Version

t Type (Cat. acc. to EN ISO 13849-1)

U Internal supply voltage

o Current chip temperature

E The last five error messages (displayed by pressing "Data")

E rES: press and hold "Data" button until --- is displayed to reset the memory of the error messages

5.6 Error displays

Display	E001	E002	E006	E007	E008	E009	E101	E102
Error	Sensor 1 wiring defective	Sensor 2 wiring defective	Configuration mode incorrectly set	①	②	① ②	Under-voltage	Overvoltage
Remedy	Check sensor 1	Check sensor 2	Check configuration	Outputs not OK			Check supply	

Should other fault messages appear, please contact your supplier.

6 Technical Data

Supply voltage	24 VAC -20% to +10%; 24 VDC -20% to +20%
Power consumption	max. 3 VA
Inputs Sensors	for Sensors with 8,2 kOhm termination
Input Reset	24 VACDC
Safety relays	Solid state relays, 24 VDC, max. 250 mA internally protected by a 300 mA fuse
Status output	Solid state relays, 24 VACDC, max. 250 mA
Reaction time (at activation)	< 5 ms
Recovery time	< 30 ms (reset after activation)

Start-up time	< 300 ms
External reset pulse (required)	> 100 ms
Housing	Polyamide grey / red
Dimensions	22,5 x 94 x 88 mm (W x H x D)
Mounting	Direct DIN-rail mounting
Terminals	Pluggable screw terminals
Protection class	IP30
Operating temperature	-20°C to +60°C
Storage temperature	-40°C to +70°C
Humidity	< 95% non-condensing

7 EU Declaration of Conformity

See attachment

8 WEEE



Devices with this symbol must be treated separately during disposal. This must be done in accordance with the laws of the respective countries for environmentally sound disposal, processing and recycling of electrical and electronic equipment.

8 Contact

BBC Bircher Smart Access, BBC Bircher AG, Wiesengasse 20, CH-8222 Beringen, www.bircher.com

Designed in Switzerland / Made in EU