

LBDoor TB12.P

Single-beam miniature photoelectric sensor with fixed cable

Original operation instruction

General



Dimensions

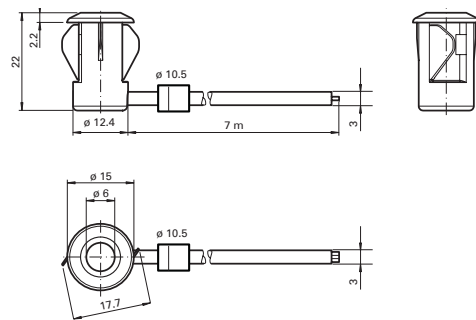

Product information

There is no simpler way of installing a sensor: drill the hole, clip in the sensor and you're done. What's more, LBDoor TB12.P plug-in sensors for doors and turnstiles offer top performance at an extremely attractive price. The switching mechanism is integrated in the compact, self-contained and temperature-stable housing, making LBDoor TB12.P suitable even for extremely cold regions with temperatures as low as -40°C.

Features

Single-beam miniature photoelectric sensor, ideal for installing in frames or contours

- Integrated circuit
- Plug-in style housing for 13 mm hole
- Narrow opening angle, suitable for mounting in pairs
- Dark on version also available
- Version with test input

Typical applications

- Monitoring function for turnstiles
- Activation function for restarting escalators
- Monitoring of industrial gates
- Person detection for automatic doors and gates

1 Safety instructions

The unit may only be installed and commissioned by trained and qualified personnel.
The unit may only be opened and repaired by the manufacturer.



This unit may only be operated from a protective low-voltage with safe electrical isolation.
Always consider the safety functions of your application as a whole, never just in relation to one individual component of the system.
The installer is responsible for carrying out a risk assessment and installing the detector and the system correctly.
Avoid touching any electronic components.

2 Electrical connection – Indicators / operating means

Electrical connection

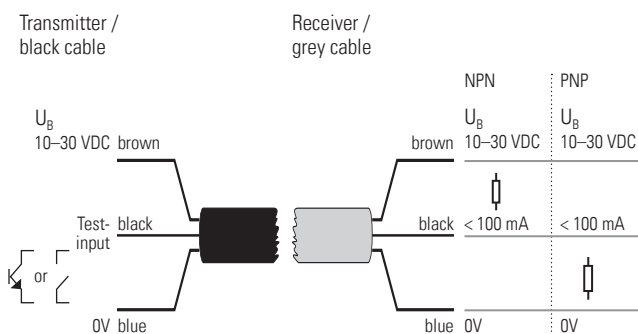

Indicators / operating means

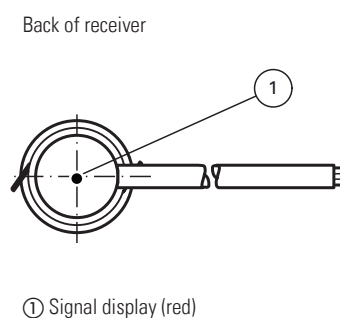

3 Technical data

General specifications	
Detection range	0–6 m
Light source	IREd
Light type	Modulated infrared light , 880 nm
Diameter of the light spot	Approx. 1300 mm at a distance of 6 m
Angle of divergence	Emitter: +/- 8 ° Receiver: +/- 10 °
Optical face	Frontal
Ambient light limit	Halogen light 100000 Lux; according to EN 60947-5-2:2007

Functional safety related parameters	
MTTF _d	795 a
Mission Time (T _M)	20 a
Diagnostic Coverage (DC)	0 %

Indicators	
Function indicator	LED red: lights up when receiving the light beam; flashes when falling short of the stability control; OFF when light beam is interrupted

Electrical specifications	
Operating voltage U _B	10 – 30 V DC
No-load supply current I ₀	Emitter: ≤ 20 mA Receiver: ≤ 10 mA

Input	
Test input	Threshold < 1.4 V (emitter deactivation)

Output	
Switching type	Light on
Signal output	1 PNP output, short-circuit protected, reverse polarity protected, open collector
Switching voltage	Max. 30 V DC
Switching current	Max. 100 mA
Voltage drop U _d	≤ 1.5 V DC
Switching frequency f	62.5 Hz
Response time	8 ms

Ambient conditions	
Ambient temperature	-40 – 60 °C (-40 – 140 °F), fixed mounted -20 – 60 °C (-4 – 140 °F), movable mounted
Storage temperature	-40 – 70 °C (-40 – 158 °F)
Relative humidity	90 %, noncondensing

Mechanical specifications	
Degree of protection	IP67
Connection	0.15 / 7 m PVC connection cable with 3-pin JST connector Receiver: grey; Emitter: black
Material	
Housing	PC, black
Optical face	Plastic pane
Weight	Approx. 100 g per device

Approval	
CCC approval	CCC approval / marking not required for products rated ≤ 36 V

4 Curves / Diagrams

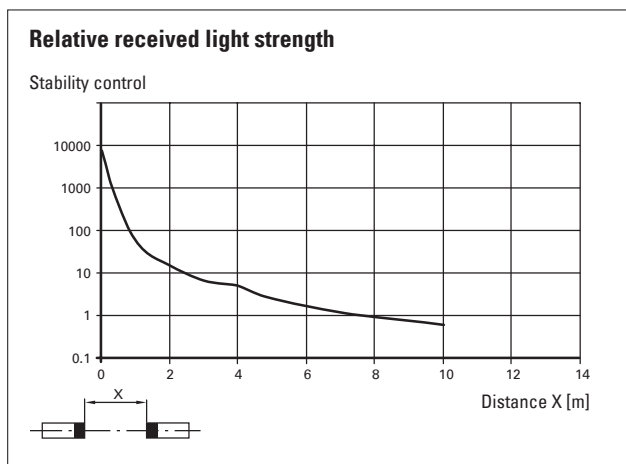
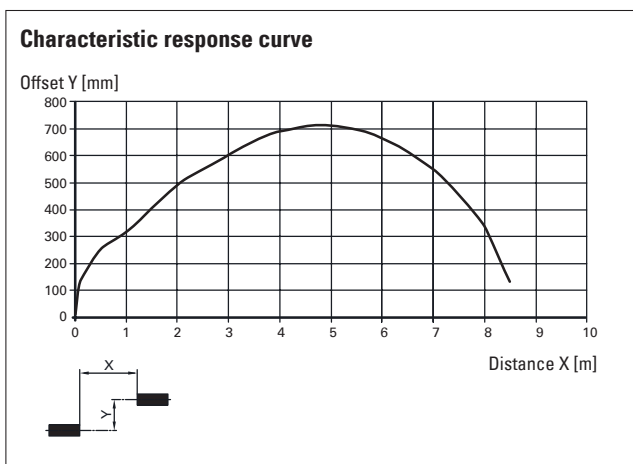

5 Operating principle

The thru-beam sensor requires two devices for operation; a light source and a light receiver. The light source and receiver must be optically aligned with one another in a single line. The infrared light emitted from the source is recorded by the receiver and evaluated.

The sensor detects both people and objects for as long as an object interrupts the detection beam, regardless of movement and surface structure.

6 Function

The series LBDoor TB12.P light beam sensor requires a pair of devices for operation, comprising a light transmitter and a light receiver. The transmitter and receiver must be arranged in optical alignment with each other. The infrared light from the transmitter is detected by the receiver and evaluated.

Static detection:

The light beam sensor detects persons and objects independently of movement and surface structure for as long as the object breaks the detection beam.

Output (black wire of receiver)

State	LBDoor TB12.N	LBDoor TB12.D.N	LBDoor TB12.P	LBDoor TB12.D.P	Signal display (red)
Unpowered	open	open	open	open	off
Not aligned	open	0V	open	U_B	off
Idle (ok)	0V	open	U_B	open	ON
Object	open	0V	open	U_B	off
Testing	open	0V	open	U_B	off

Installation:

Thanks to its small dimensions, the light beam can be fitted in a U-profile or behind a face panel.

Sheet thickness [mm]	Hole diameter [mm]	
	13	13.5
1	OK	X
2	OK	OK
3	OK	OK

X = Mounting is not possible OK = Mounting possible

Installation of twin-beam arrangement:

A twin-beam version requires 2 transmitters and receivers. When using thru-beam sensors with the same transmission frequency: Ensure that **the minimum beam distance is 20 cm** and that the light source and receiver are arranged in a cross formation.

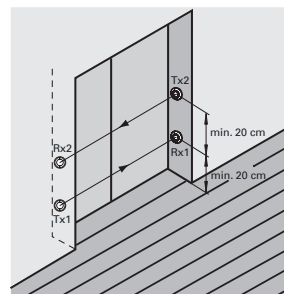

7 EU Declaration of Conformity

 See attachment

8 WEEE



Devices with this symbol must be treated separately during disposal. This must be done in accordance with the laws of the respective countries for environmentally sound disposal, processing and recycling of electrical and electronic equipment.

9 Contact

BBC Bircher Smart Access, BBC Bircher AG, Wiesengasse 20, CH-8222 Beringen, www.bircher.com

Made in Vietnam

